

**Taikan**

## High-precision CNC horizontal Turning (Milling) Lathe

High-speed High-efficiency High-precision

D-L35/D-L35M/D-L35Y

D-L45/D-L45M/D-L45Y

D-L3505/DL3505MSY

D-L4505

**Taikan**

HIGH-END INTELLIGENT EQUIPMENT TURN-KEY SOLUTION SERVICE PROVIDER

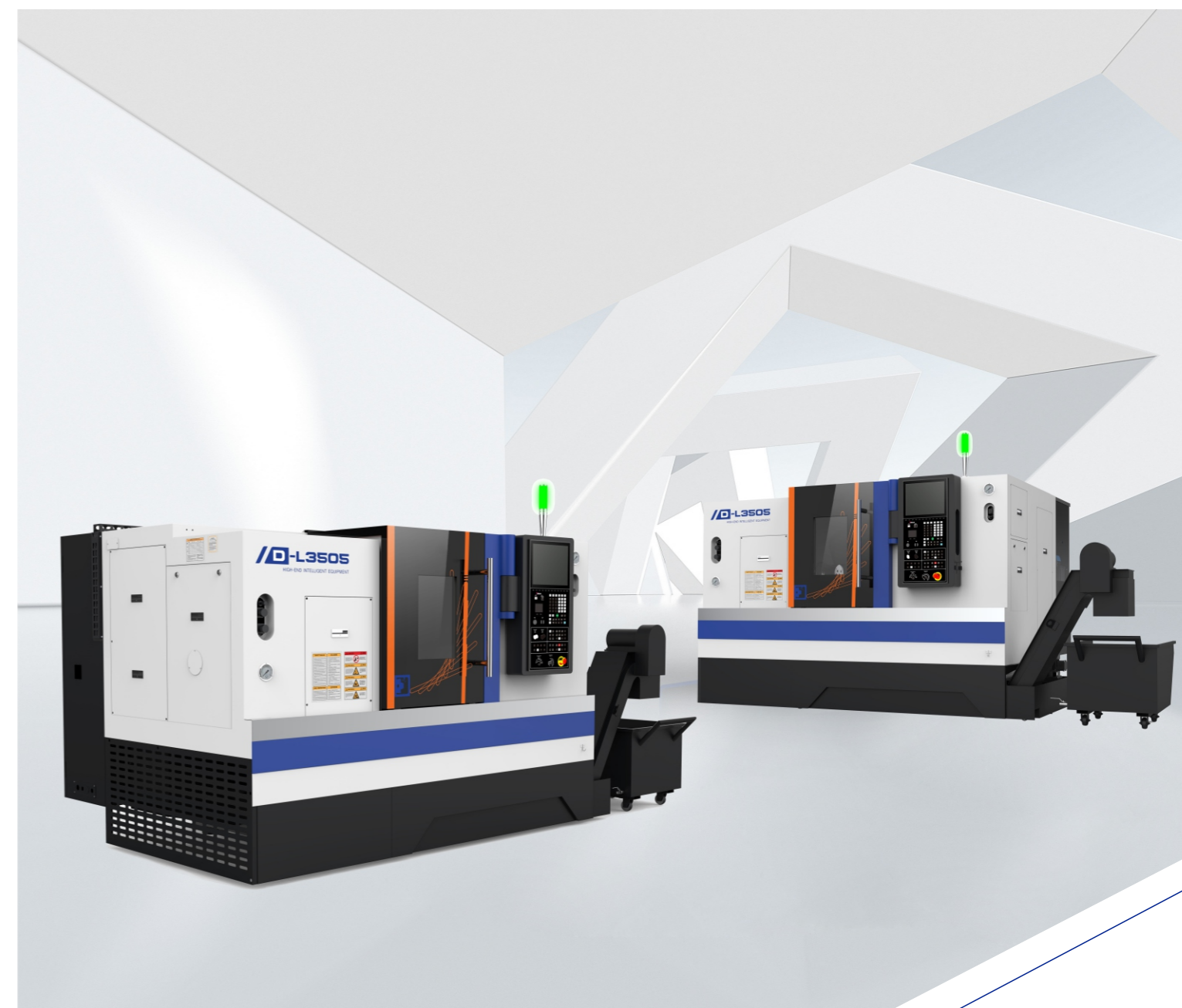

SHENZHEN CREATE CENTURY AUTOMATION TECHNOLOGY CO., LTD.  
Address: No.154, Nanpu Road, Xinqiao Street, Bao'an District, Shenzhen, Guangdong, China  
Tel: 0755-27255933  
E-mail: overseas@szccm.com  
Official Website: www.taikanmachine.com

HIGH-END INTELLIGENT EQUIPMENT TURN-KEY SOLUTION SERVICE PROVIDER

## Features & Technology

Structure & Configuration

Options & Highlights

Parameters & sizes

Machine appearance diagram

High-precision CNC horizontal Turning (Milling) Lathe

# D-L35/D-L35M/D-L35Y D-L45/D-L45M/D-L45Y

- ★ The structural design of the 30° inclined bed saddle has high rigidity and good stability.
- ★ The integrated high-rigidity spindle structure has high positioning accuracy, low noise, and the spindle runout is within 0.003mm.
- ★ X and Z-axis screws adopt imported C3-level bidirectional preload hollow screws, which are high-speed and silent, with a rapid movement speed of 30m/min, fast response speed and high positioning accuracy.
- ★ Designed according to ergonomic principles, swing-type operation panel.
- ★ vAutomate multiple options to achieve higher production efficiency.



High-speed  
High-efficiency  
High-precision



## Diversified application fields

It is widely used in the processing of small and medium-sized discs, shafts and other rotary parts. It has strong processing performance and high positioning accuracy. It is especially professional in metal fields such as gears, bearings, small wheel hub units, new energy, petroleum industry, and automobile parts. Processing advantages



Flange



Pulley



Gear



Brake disc set



Wheel hub

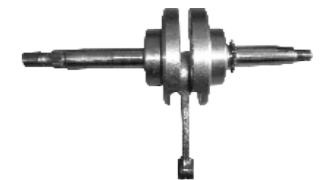

Connecting rod shaft



Features & Technology

**Structure & Configuration**

Options & Highlights

Parameters & sizes

Machine appearance diagram

High-precision CNC horizontal turning (milling) lathe

### Equipment structure technical description

30° high and low rail overall bed structural characteristics  
Perfect rigidity, high stability and high load-bearing capacity

- ★ The structural characteristics of the overall machine bed with 30° high and low rails. After finite element analysis, the layout of the reinforcing ribs is optimized, so that the machine tool has excellent rigidity, low vibration, and at the same time achieves the smallest floor space.
- ★ All castings undergo long-term natural aging treatment, and undergo secondary vibration aging treatment before finishing to eliminate residual stress inside the castings and ensure long-lasting and stable accuracy.
- ★ The X/Z axis adopts imported P-class heavy-duty 35mm roller guide rail with large span structure design, which can meet high-load operations.

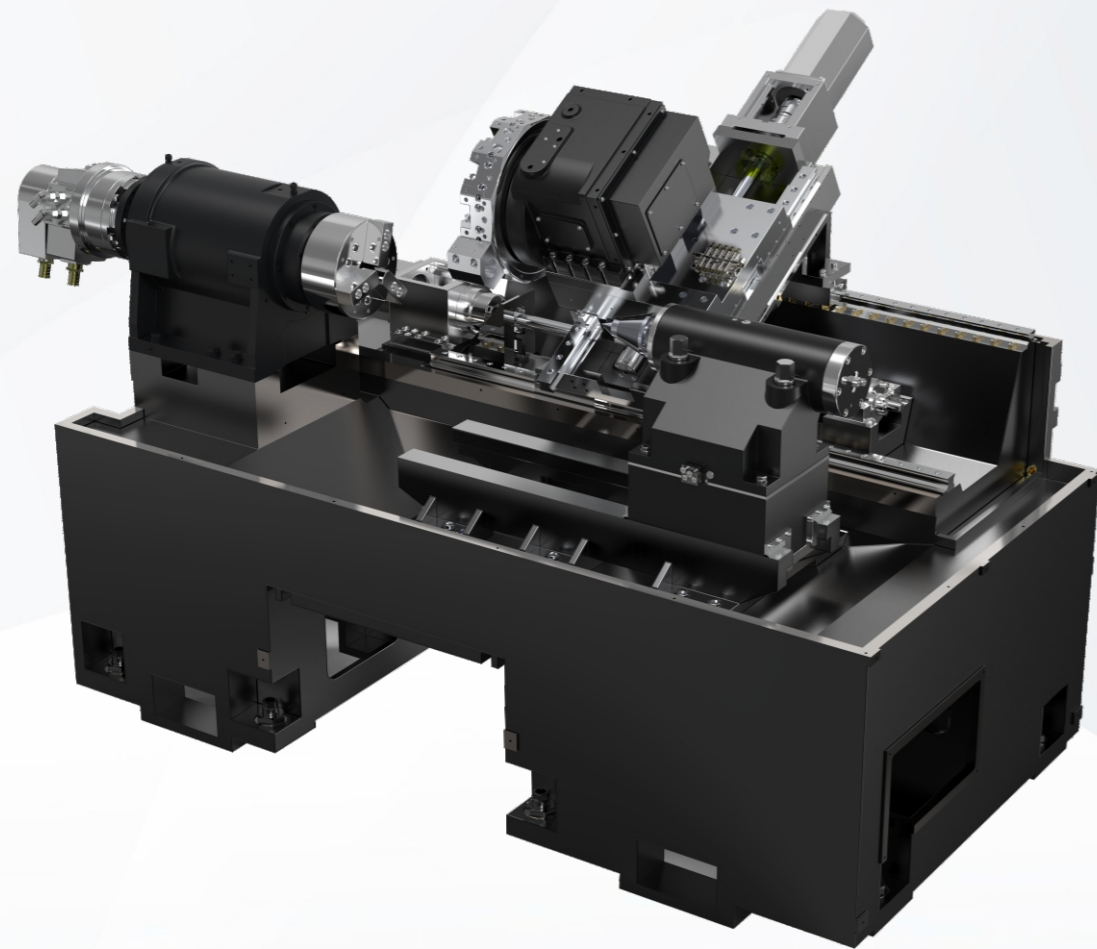

High-precision CNC horizontal turning (milling) lathe

### EQUIPMENT STRUCTURE TECHNICAL DESCRIPTION

Configuration for high-end and safe processing

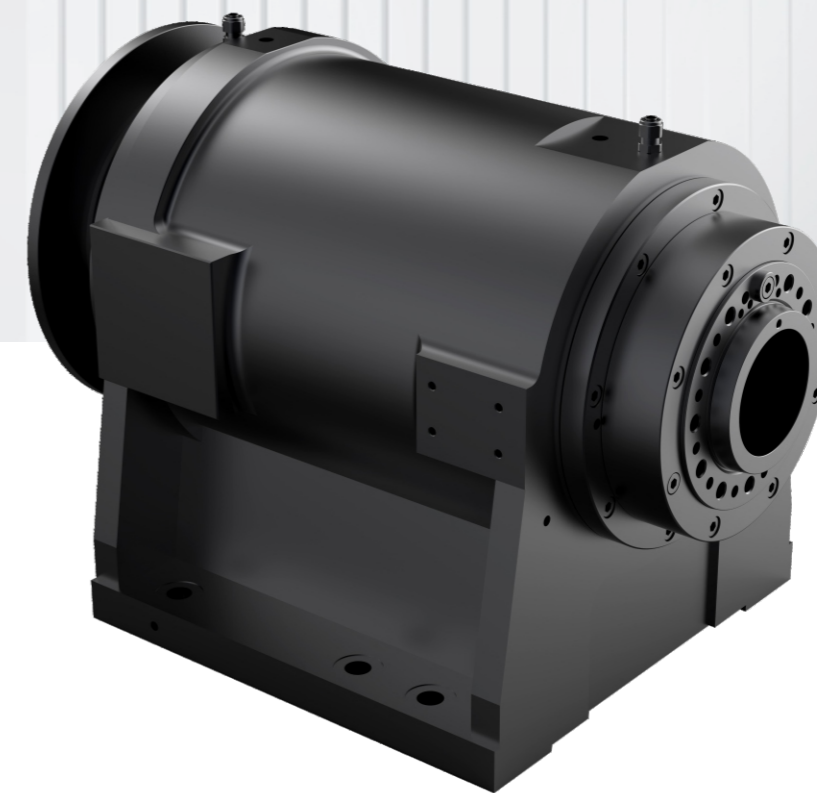

#### Features of motorized spindle

- It adopts P4 grade special bearings for machine tools and is lubricated with special bearing grease to maintain good accuracy and long service life.
- The characteristics of high rigidity and high torque of the motorized spindle greatly improve production and processing efficiency and achieve excellent re-cutting effect of the spindle.
- The spindle is directly driven by a built-in motor, with compact structure, reduced transmission error, high positioning accuracy and good stability.
- The spindle components are water-cooled or oil-cooled to reduce the impact of spindle heating on machining accuracy.



High-precision CNC horizontal turning (milling) lathe  
**Equipment structure technical description**  
 Configuring the Genesis system

★ A2-6 motorized spindle power torque diagram

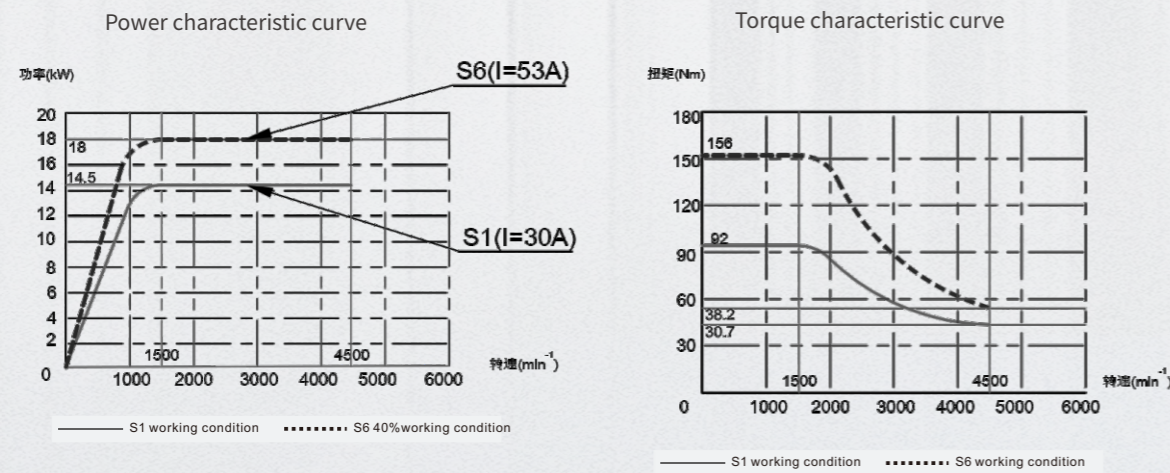

★ A2-8 motorized spindle power torque diagram

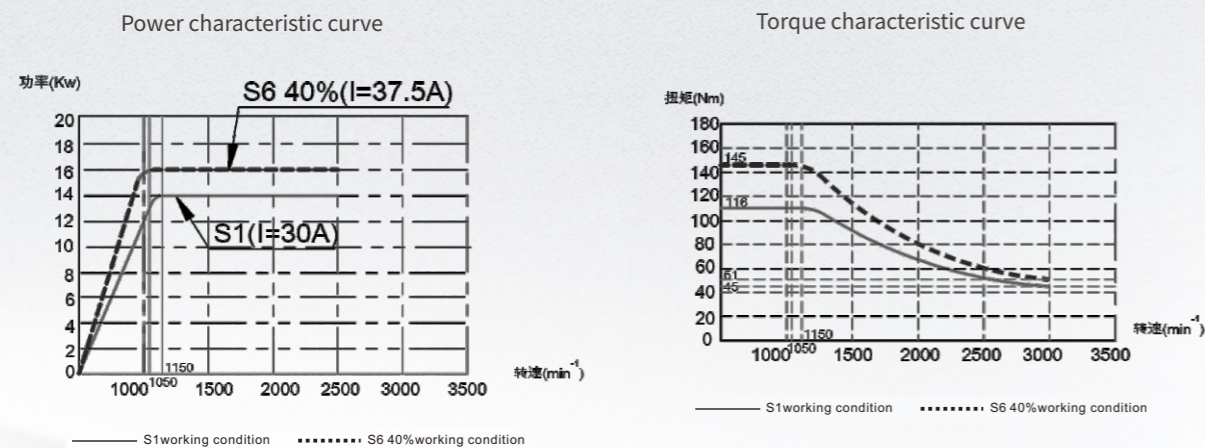

High-precision CNC horizontal turning (milling) lathe  
**Equipment structure technical description**  
 Hollow cooling screw

- ★ No cooling and water cooling have obvious effects on the thermal deformation of the screw rod.
- ★ In the case of water coolant, the thermal deformation of the screw is smaller and the accuracy of the screw is more stable.

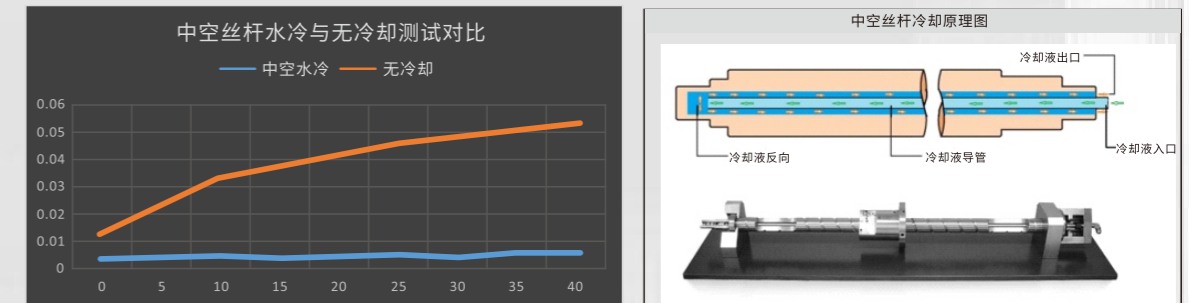

Note: The above are test data and are not used as machine tool accuracy standards.

**Precision screw and guide rail**

- ★ The X/Z axis uses an imported 32 high-speed silent ball hollow screw. The screw adopts a pre-stretching process to effectively reduce the impact of screw heating on transmission accuracy.
- ★ Rapid feed can reach 30m/min, positioning accuracy is 0.003mm; X/Z axes all use 35mm roller

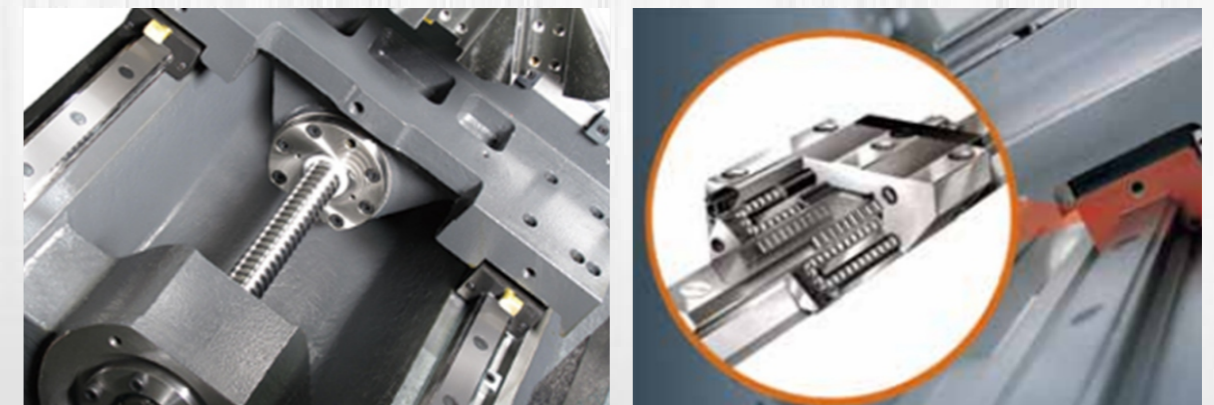



High-precision CNC horizontal turning (milling) lathe

**Equipment structure technical description**

Servo turret

- ★ The standard tool turret is driven by a servo motor and has an internal reduction mechanism for precise and reliable movement.
- ★ The tool turret can rotate in both directions, and the response speed of tool change is fast and smooth.
- ★ Three-piece end gear plate, no lifting required for tool change, good protection; hydraulic clamping, large clamping force, stable and reliable, suitable for heavy cutting.
- ★ Equipped with special tools to effectively avoid iron filings and significantly increase tool life.

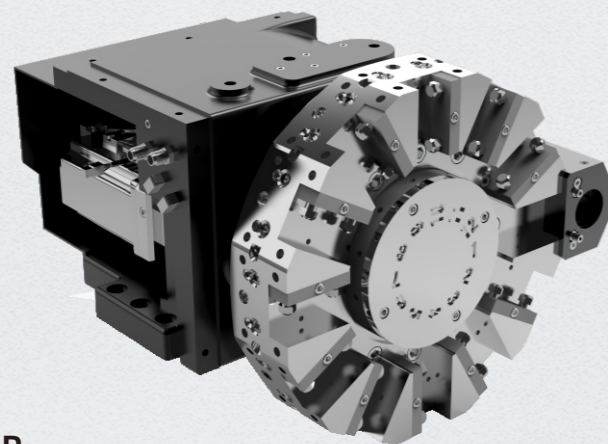

**PARAMETER**

Tool capacity	12
Tool indexing time	0.18s
External tool size	25X25mm
Max. boring tool diameter	Φ40mm
Positioning accuracy	±4"
Repeatability	±1.6"

High-precision CNC horizontal turning (milling) lathe

**Equipment structure technical description**

Powered turret

- ★ The cutterhead rotation is driven by a servo motor and has an internal deceleration mechanism, making the movement precise and reliable.
- ★ The tool turret can rotate in both directions, and the response speed of tool change is fast and smooth.
- ★ Three-piece end gear plate, no lifting required for tool change, good protection effect
- ★ Hydraulic clamping, large clamping force, stable and reliable, suitable for heavy cutting. The rotation of the power head is driven by a special motor for turning and milling, and the bevel gear inside is driven by an elastic gear.
- ★ Perfectly matched to eliminate noise generated at high speeds
- ★ Adopt carburized grinding cam and dividing mechanism. High precision and low failure rate. The power transmission shaft is made of ground titanium steel with high strength and high transmission efficiency.

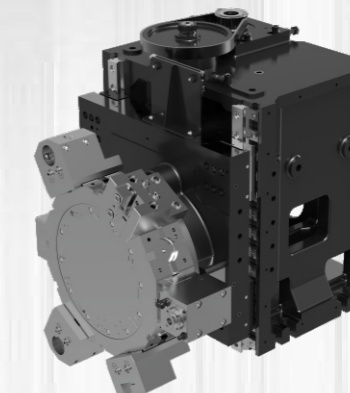
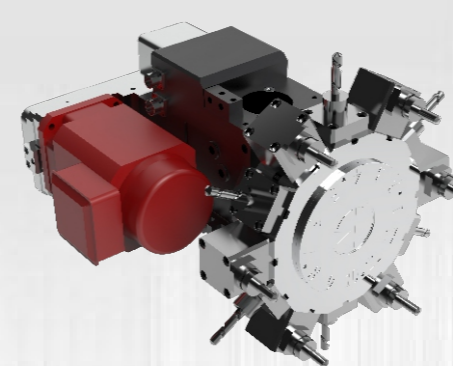

**PARAMETER**

Tool capacity	12
Tool indexing time (one/full)	0.3s
External tool size	25X25mm
Maximum boring tool diameter	BMT45-φ32mm、BMT55-φ40mm
Maximum speed of tool axis	4000rpm
Positioning accuracy	±4"
Repeatability	±1.6"



High-precision CNC horizontal turning (milling) lathe

**Equipment structure technical description**

Tool holder type



Power tower specifications		BMT45	BMT55	BMT65
Please refer to the power motor power (rated)		2.2kw	3.7kw	5.5kw
Drilling d (mm) * a (mm/u)		14 X 0.15	20 X 0.2	22 X 0.2
Tapping d (mm) * p(mm)		M10 X 1.5 M24 X 1	M16 X 2 M24 X 1.5	M18 X 2 M27 X 1.5
Milling d(mm) * p(mm)*a(mm/min)		20 X 10 X 40	25 X 14 X 40	25 X 20 X 40

Specific processing parameters depend on the processing material and power of the power motor.

High-precision CNC horizontal turning (milling) lathe

**Equipment structure technical description**

Hydraulic telescopic tailstock

- ★ Large-span hard rail structure design, strong rigidity and strong load-bearing capacity
- ★ Rectangular guide rail structure, more reliable when the lower plate is locked.
- ★ The sleeve has a long stroke, hydraulically controls the workpiece, and the control force is adjustable. Meet the processing needs of different types of products.

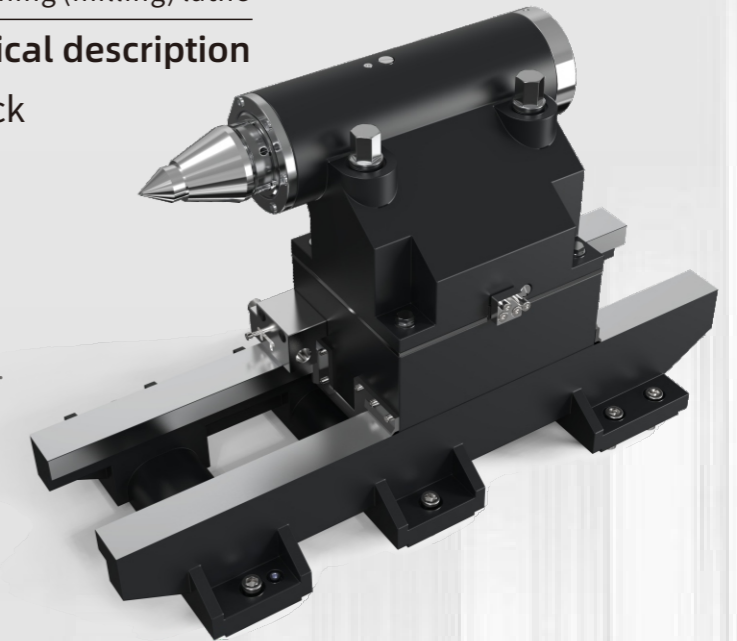

15-inch color-body operation panel

- ★ The use of Genesis CNC system maximizes user productivity.
- ★ The newly upgraded operation panel adopts universally designed buttons and layout to enhance operational convenience. Optional easy-to-enter push button switch, new ergonomic design.

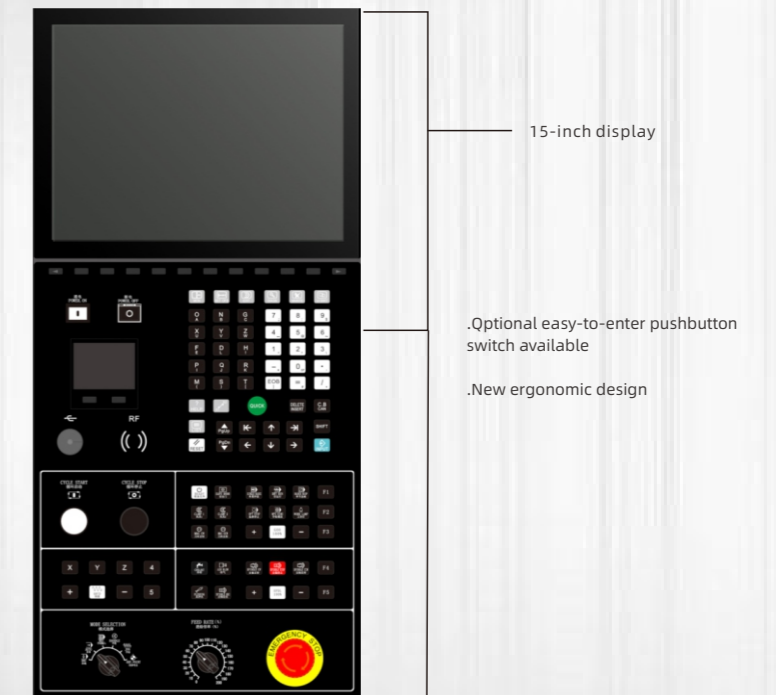

15-inch display

.Optional easy-to-enter pushbutton switch available

.New ergonomic design



High-precision CNC horizontal turning (milling) lathe

**Equipment structure technical description**

Tool holder type

- ★ High rigidity structure and high clamping accuracy. The sliding surfaces are hardened, precision ground, and directly lubricated.
- ★ The wedge-shaped three-jaw design of the chuck is particularly suitable for clamping special-shaped objects.



Rich option configuration

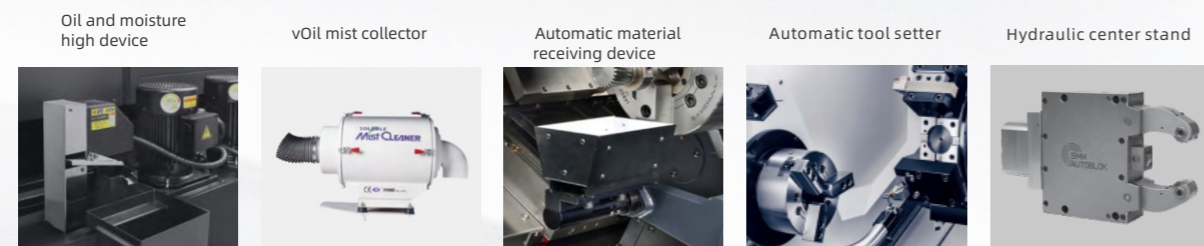

High-precision CNC horizontal turning (milling) lathe

**Equipment structure technical description**

Processing test comparison (all are on-site proofing data)



Re-cut test				
Tool angle/arc: 80 degree outer circle tool/R0.8 spindle speed S1000				
Feed (G99)	Cutting amount per side	Processing size	Spindle load	Processing conclusion
F0.4	5MM	Φ56X50	117%	Normal, no vibration of the spindle
F0.35	4MM	Φ66X50	96%	

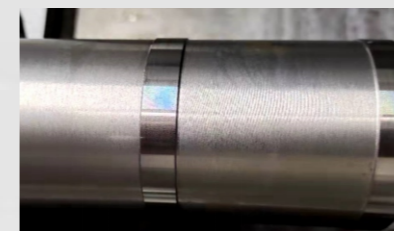

Roundness/Taper Change Test			
Tool name/angle/arc angle: outer diameter/35°/R0.4 spindle speed S1500			
Feed (G99)	Cutting amount per side	Processing size	Processing conclusion
F0.05	0.05MM	131	Normal
Inspection items	Inspection tools/methods	Reference values for national standard parts	Actual measured values: roundness
Front roundness	3D /Micrometer	0.003	0.0016
Center roundness			0.0018
Back roundness			0.002



Line profile change test			
Tool name/angle/ arc angle	Spindle speed	Feed (G99)	Cutting amount per side
Cylindrical nut/35/R0.4	S1500	F0.05, precision	0.04mm
National standard parts reference value		Actual value	
0.045		0.0125	

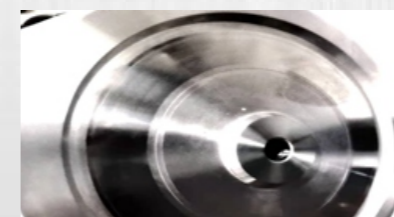

Flatness change test			
Tool name/angle/arc angle Outside: Angle/35°/R0.4 Spindle speed S1200			
Feed (G99)	Cutting Amount/ Single Side	Extension	Processing Conclusion
F0.05	0.05MM	35	Normal
Inspection items	Inspection tools/methods	National standard parts reference values	Actual measured values
End surface flatness	three-dimensional	0.022 (concave in the middle)	Concave 0.0039

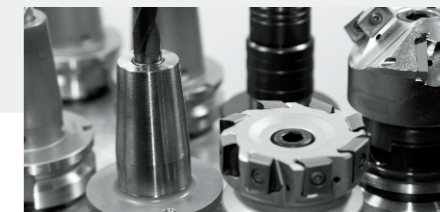

## Technology parameter

		D-L35	D-L35M	D-L35Y	D-L45	D-L45M	D-L45Y
Processing range	Max. rotation diameter (mm)	Φ550			Φ650		
	Max. processing diameter (shaft/disc)(mm)	Φ300/Φ350			Φ380/Φ450		
	Max. processing length(mm)	560	500	450	560	500	450
	Max. bar diameter(mm)	Φ52			Φ75		
Travel	X-axis travel(mm)	190			240		
	Y-axis travel(mm)	/		100(±50)	/		100(±50)
	Z-axis travel(mm)	580	530	500	580	530	500
Motorized spindle	Output power(S1/S6)(kw)	14.5/18			14/16		
	Spindle end form	A2-6			A2-8		
	Spindle speed(rpm)	0-4500			0-2500		
	Spindle through hole diameter(mm)	Φ67			Φ103		
Tool holder	Tool form and tool capacity	Servo /12	Power /12		Servo /12	Power /12	
	Max. speed of power tool(rpm)	/	3000		/	3000	
	Specifications(mm)	/	BMT45	BMT45 <small>(With independent Y axis)</small>	/	BMT55	BMT55 <small>(With independent Y axis)</small>
	Turning tool holder specifications(mm)	25×25			25×25		
	Max. diameter of boring tool holder(mm)	Φ40	Φ32		Φ40		
Rapid speed	Rapid speed(X/Z axis)(m/min)	30			30		
	Rapid speed(Y axis)(m/min)	/		10	/		10
Feed rate	Cutting feed rate(mm/min)	1-8000			1-8000		
Tailstock	Tailstock tapered hole form	Hydraulic sleeve/Mohs 5#			Hydraulic sleeve/Mohs 5#		
	Tailstock sleeve travel(mm)	150			150		
Control system	Nc form	Genesis System			Genesis System		
Chip conveyor		Automatic rear chip conveyor			Automatic rear chip conveyor		

All pictures in this album are for reference only and are subject to actual delivery; our company's products are constantly being improved and the above information is subject to change without prior notice.

## Technical configuration

	D-L35	D-L35M	D-L35Y	D-L45	D-L45M	D-L45Y
A2-6 motorized spindle	●	●	●	○	○	○
A2-8 motorized spindle	○	○	○	●	●	●
6-inch hollow chuck cylinder	○	○	○	△	△	△
8 inch hollow chuck cylinder	●	●	●	○	○	○
10 inch hollow chuck cylinder	○	○	○	●	●	●
12-inch hollow chuck cylinder	△	△	△	○	○	○
6 inch solid chuck cylinder	○	○	○	△	△	△
8 inch solid chuck cylinder	○	○	○	○	○	○
10 inch solid chuck cylinder	△	△	△	○	○	○
12 inch solid chuck cylinder	●	○	○	●	○	○
Servo turret	○	●	●	○	●	●
Powered turret	●	●	●	●	●	●
12 workstations	●	●	●	●	●	●
Hydraulic telescopic tailstock	○	○	○	○	○	○
Programmable tailstock	○	○	○	○	○	○
Side chip conveyor (automatic)	●	●	●	●	●	●
Rear chip conveyor (automatic)	○	○	○	○	○	○
Rear chip conveyor (manual)	○	○	○	○	○	○
center frame	○	○	○	○	○	○
Tool setter	○	○	○	○	○	○
Bar machine	○	○	○	○	○	○
Automatic material receiving device	○	○	○	○	○	○
Oil mist collector	○	○	○	○	○	○
High pressure water outlet	○	○	○	○	○	○
Automatic door	○	○	○	○	○	○
Sub-spindle	○	○	○	○	○	○
Grating scale	○	○	○	○	○	○
Safety door grating	○	○	○	○	○	○

● Standard configuration ○ Optional ▲ Consultable △ Non-optional



## Processing Capacity Chart

D-L35

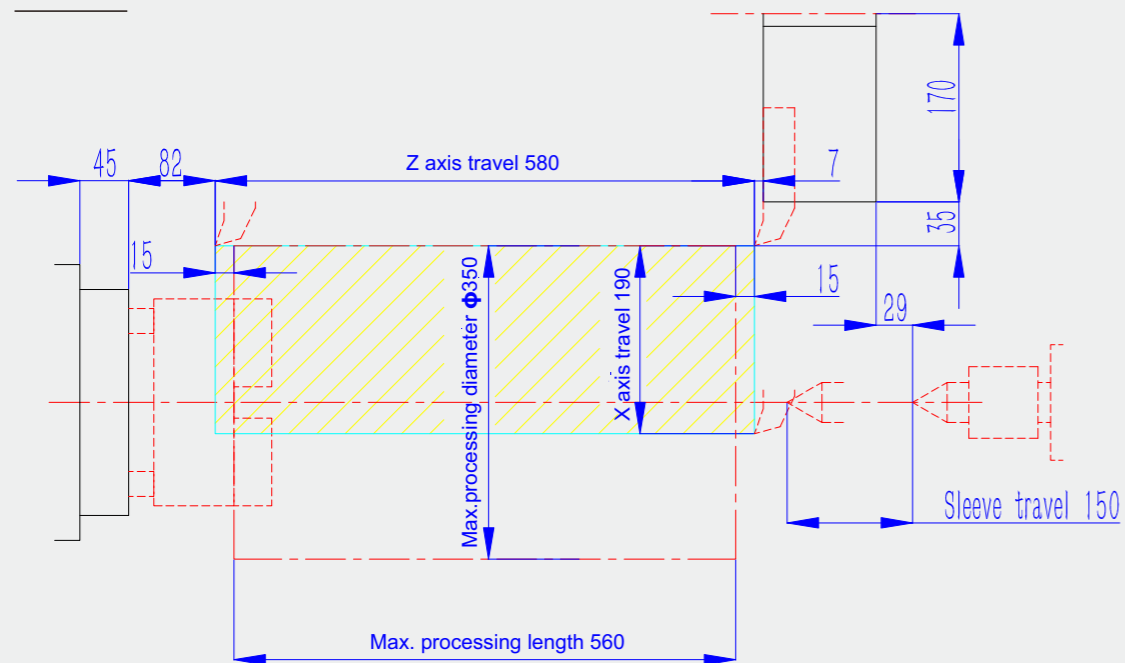

D-L45

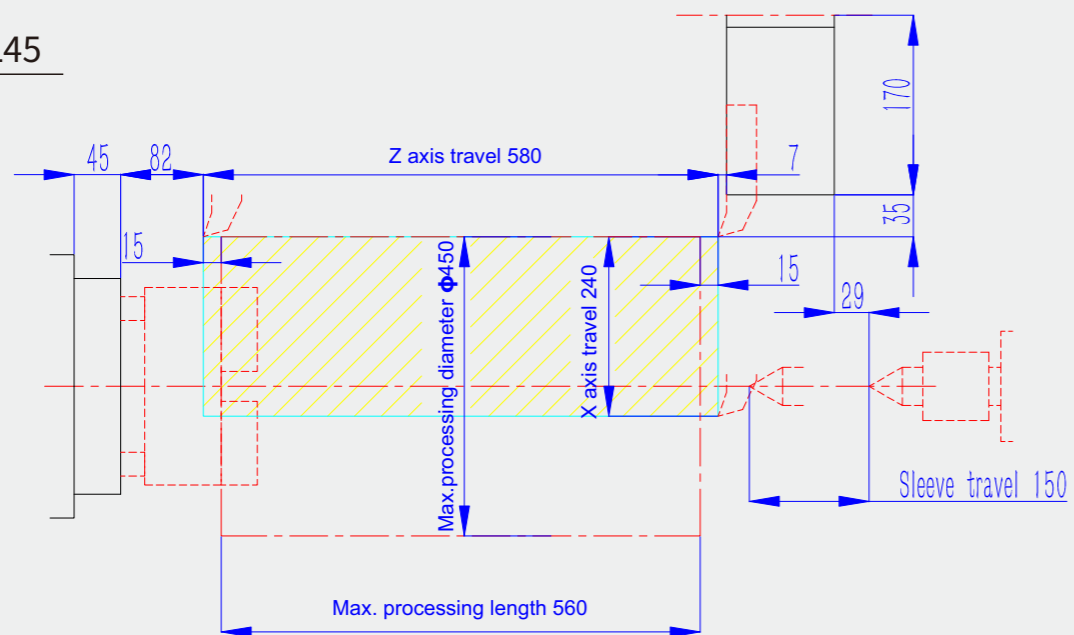

## Processing Capacity Chart

D-L35M

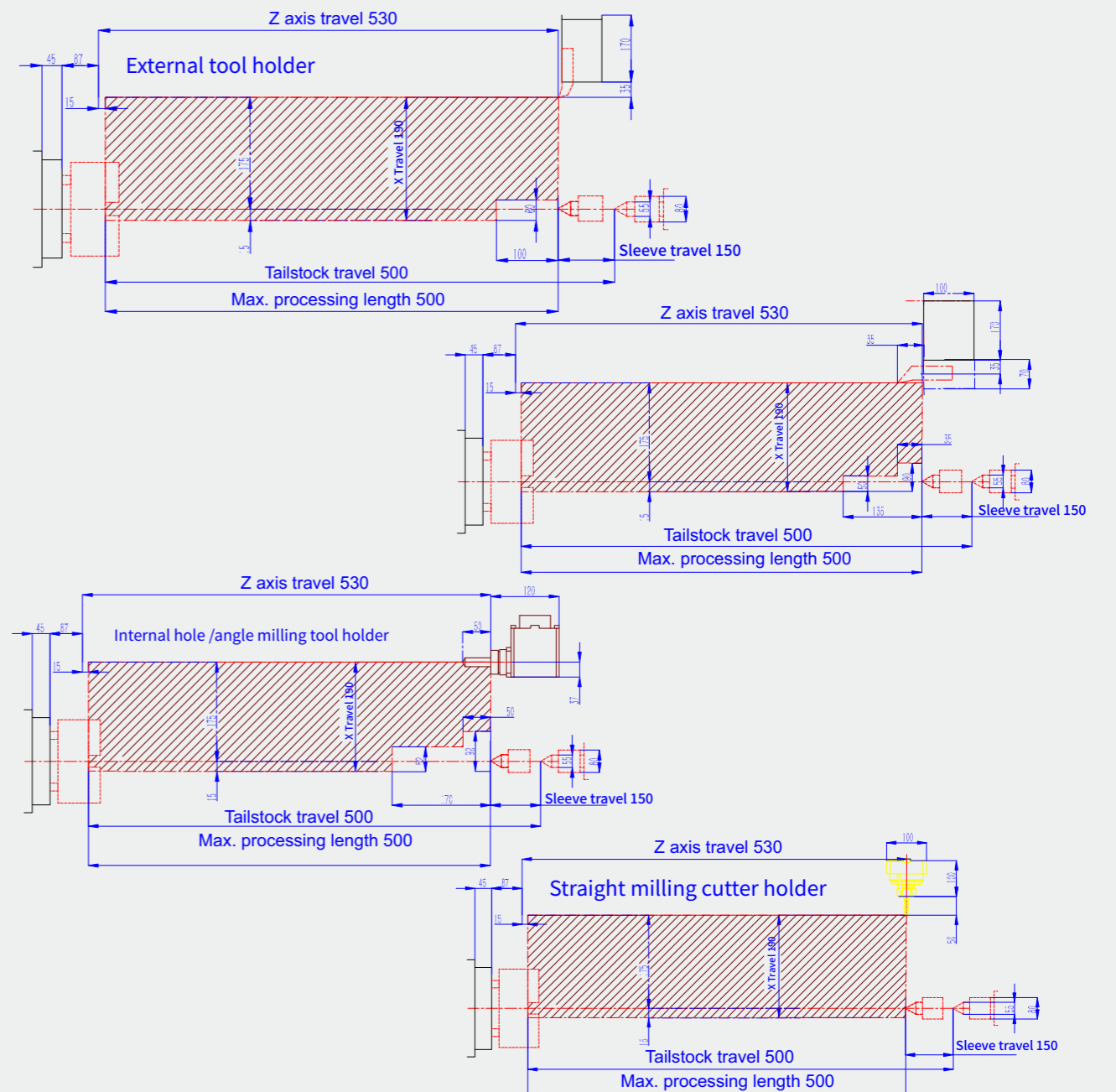





Features & Technology
Structure & Configuration
Options & Highlights
<b>Parameters &amp; sizes</b>
Machine appearance diagram

## Processing Capacity Chart

### D-L45Y

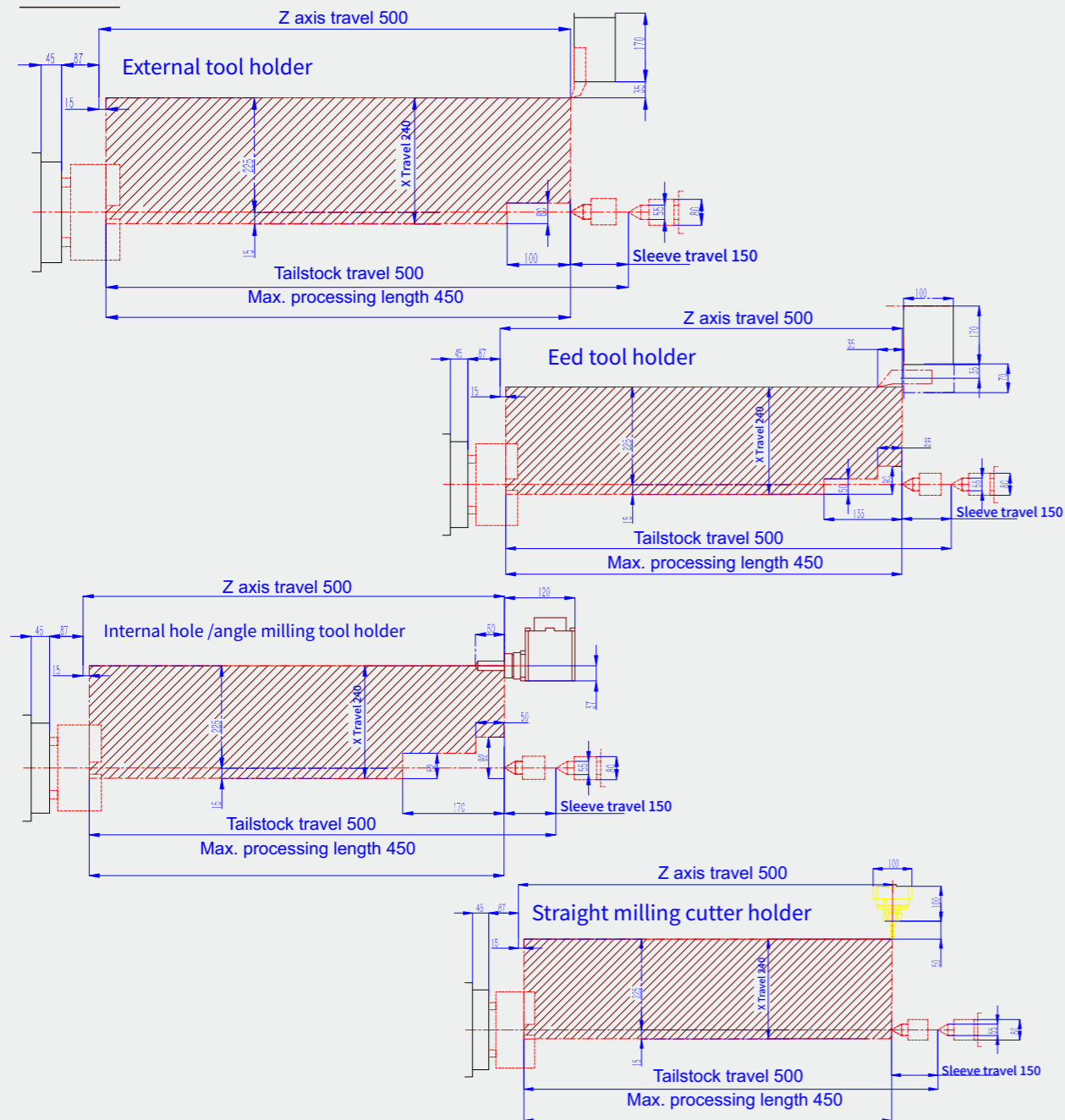

## Tool Interference Diagram

### D-L35

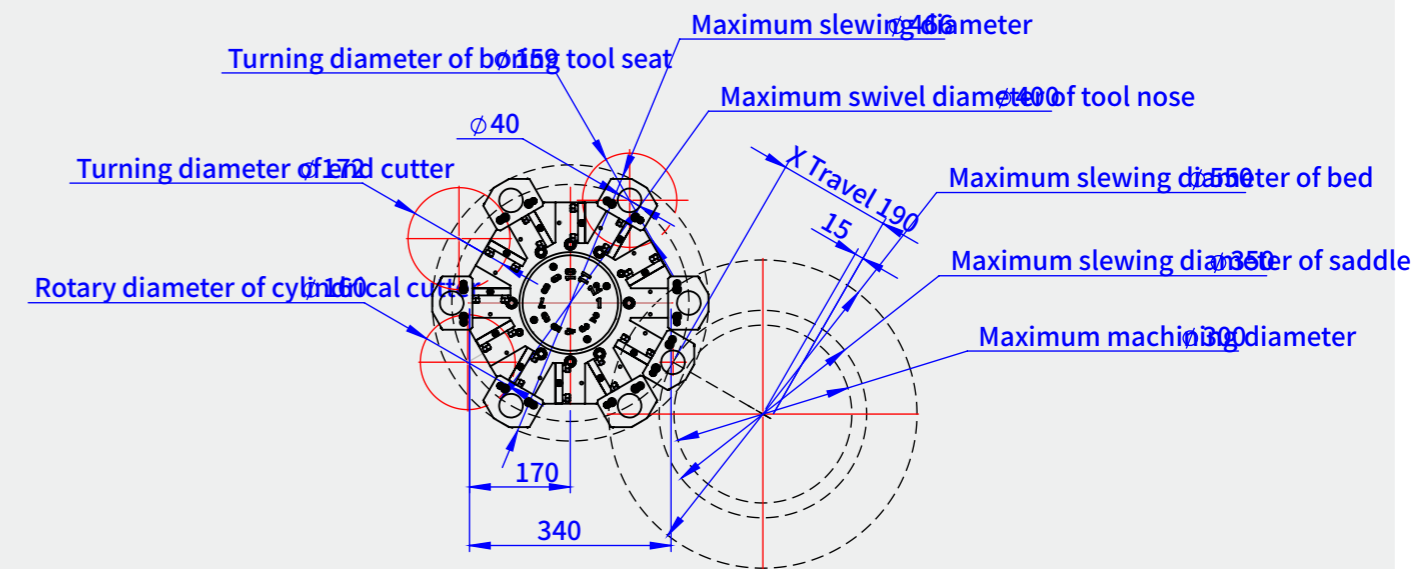

### D-L45

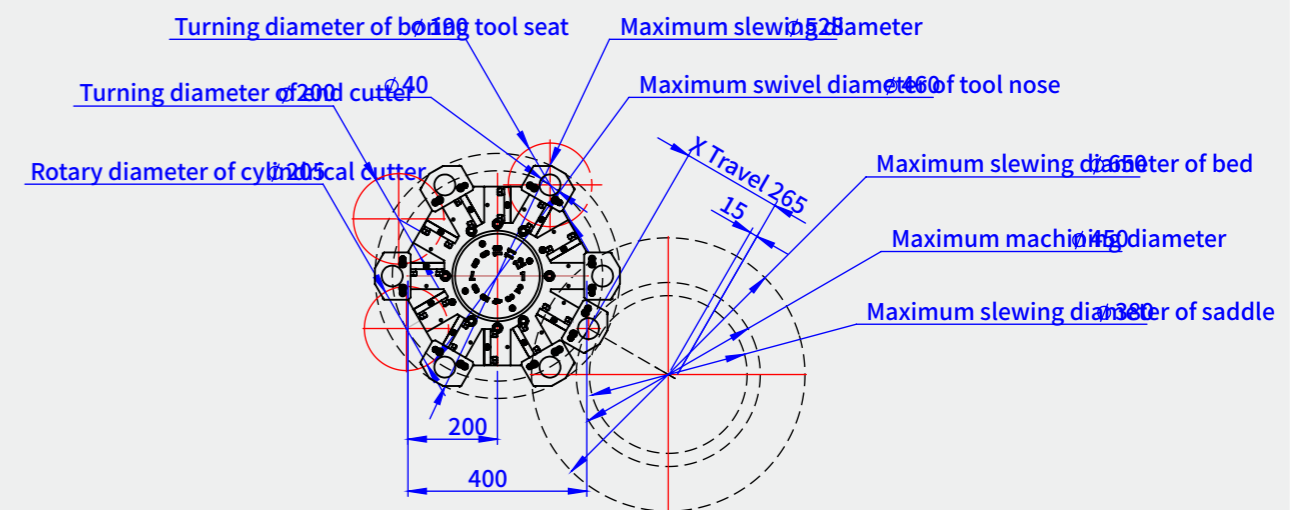

Features & Technology
Structure & Configuration
Options & Highlights
<b>Parameters &amp; sizes</b>
Machine appearance diagram

## Tool Interference Diagram

### D-L35M

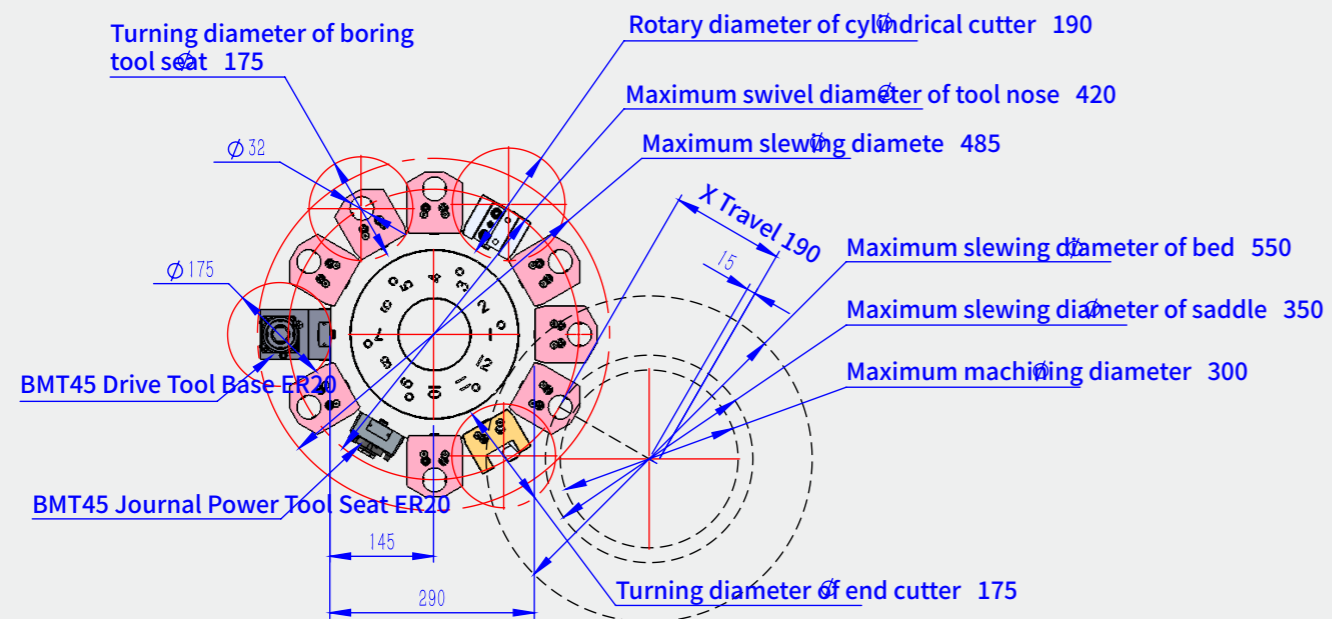

### D-L35Y

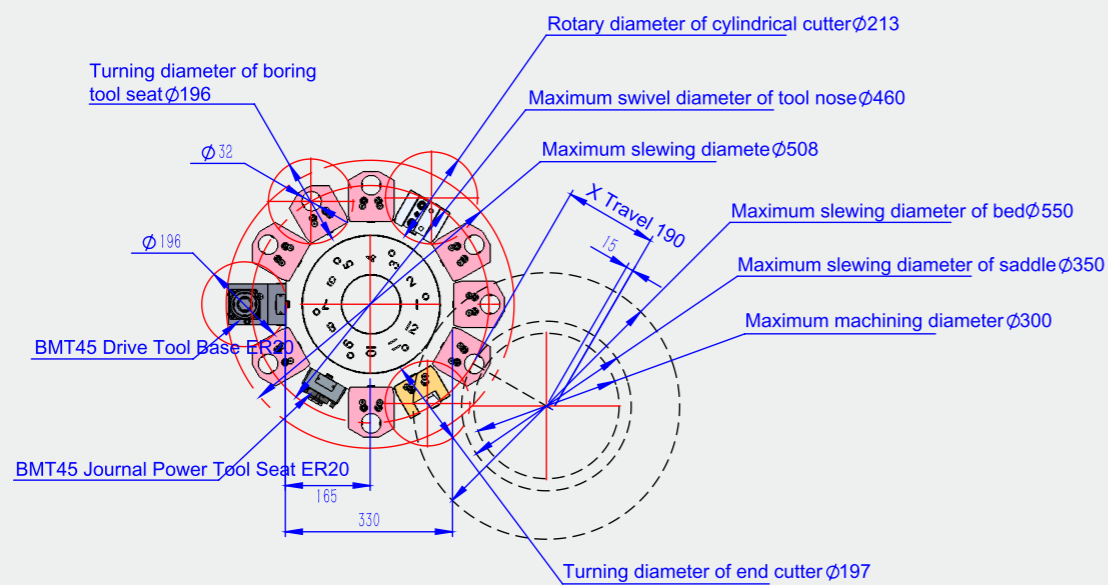

## Tool Interference Diagram

### D-L45M/D-L45Y

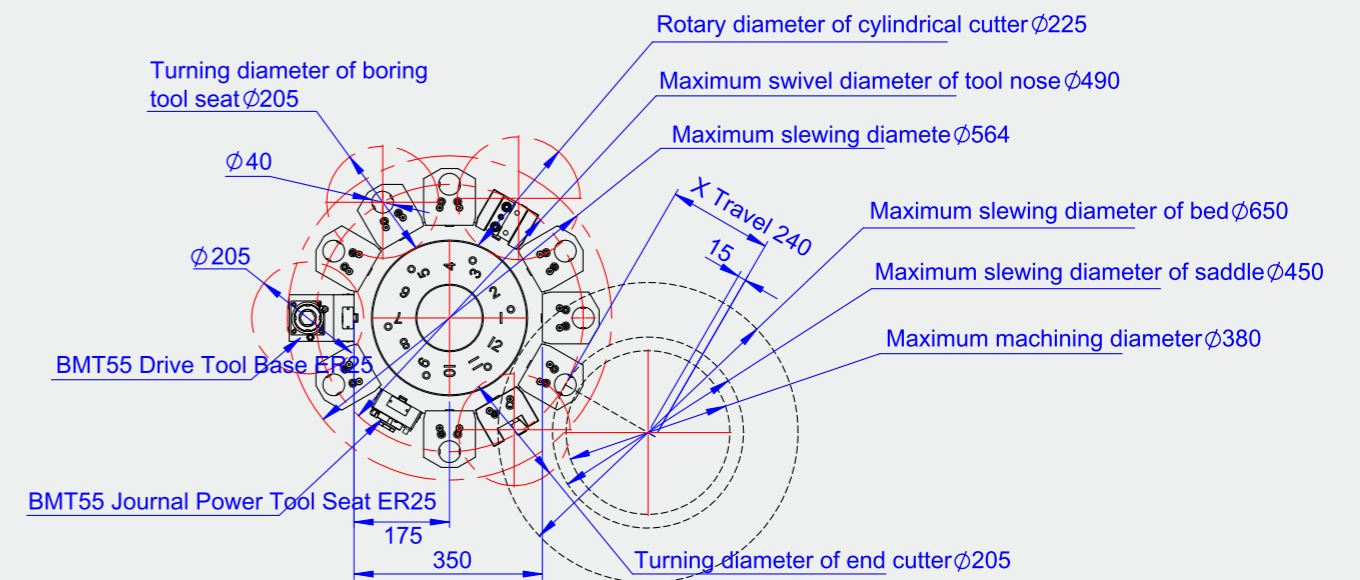



## Machine appearance diagram

D-L35/D-L45/D-L35M/D-L45M/D-L35Y/D-L45Y

Standard size

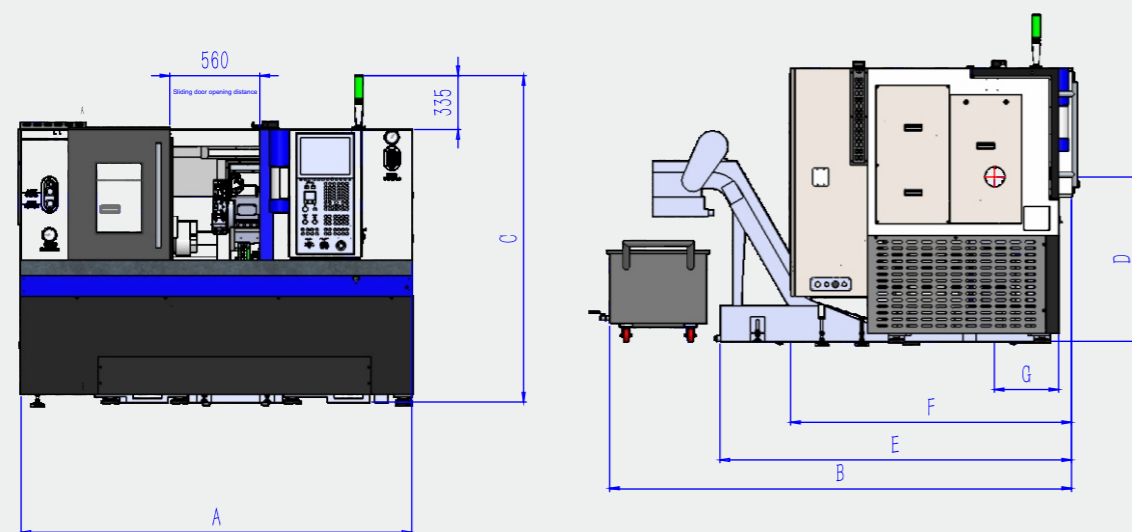

Standard size	A	B	C	D	E	F	G
D-L35	2430	2800	2030	1020	2180	1740	400
D-L45	2480	2860	2120	1085	2220	1840	400
D-L35M	2430	2800	2030	1046	2180	1740	370
D-L45M	2480	2860	2120	1110	2220	1840	370
D-L35Y	2430	2800	2230	1046	2180	1740	370
D-L45Y	2480	2860	2450	1110	2220	1840	370



**High-end intelligent equipment overall solution provider**

**Taikan**

## Features & Technology

Structure & Configuration

Options & Highlights

Parameters & sizes

Machine appearance diagram

### High-precision CNC horizontal Turning (Milling) Lathe

# D-L3505/D-L3505M/ D-L3505MS/D-L3505MSY/D-L4505

- ★ 30° integral material bed design has the advantages of high rigidity and convenient chip removal.
- ★ Integrated high rigidity, large torque, large through hole spindle, low noise and high positioning accuracy.
- ★ X/Z axes are designed with a hard rail structure. The guide rail surface is high-frequency quenched to a hardness of HRC48, and combined with low-friction, wear-resistant imported plastic-coated guide rail soft belts, it has good motion accuracy and dynamic characteristics.
- ★ The tailstock adopts rectangular guide rail, the guide rail surface has HRC48 hardness surface heat treatment, and has good load-bearing rigidity.
- ★ Designed according to ergonomic principles, using a swingable operation panel
- ★ Automate multiple options to achieve higher production efficiency.



High-speed  
High-efficiency  
High-precision



### Diversified application fields

Impellers, precision molds, medical equipment, automotive parts, aerospace parts, die castings, military parts



Impeller

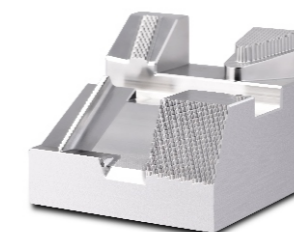

Combination pattern inserts



Locating ring



Car light pattern inserts



Medical parts



Hydraulic valve body



High-precision CNC horizontal turning (milling) lathe

**Equipment structure technical description**

30° overall inclined bed structural characteristics

Perfect rigidity, high stability and high load-bearing capacity

- ★ The structural characteristics of the 30° integral bed slant body. After finite element analysis, the layout of the reinforcing ribs is optimized, so that the machine tool has excellent rigidity and low vibration, while achieving the smallest floor space.
- ★ All castings undergo long-term natural aging treatment and undergo secondary vibration aging treatment before finishing to eliminate residual stress inside the castings and ensure long-lasting and stable accuracy.
- ★ The X and Z axis screws adopt imported C3-level bidirectional preload hollow screws, which are high-speed and silent, with a rapid movement speed of 20m/min, fast response speed and high positioning accuracy.

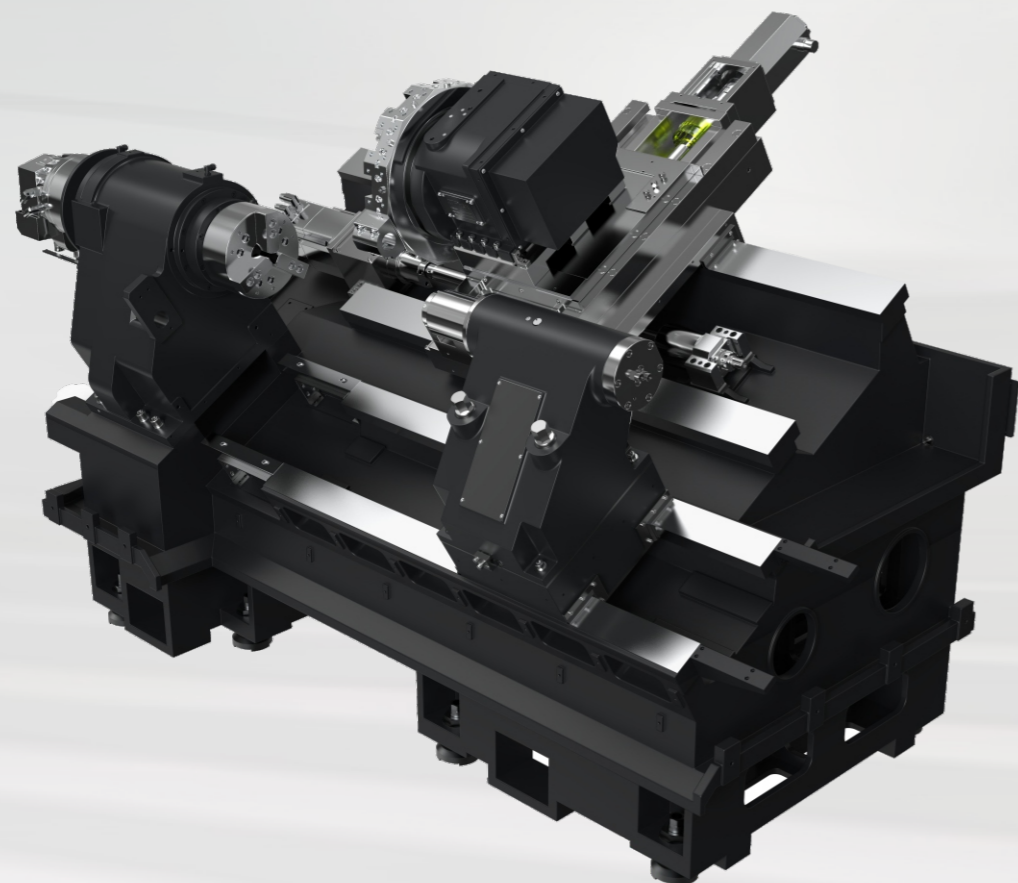

High-precision CNC horizontal turning (milling) lathe

**Equipment structure technical description**

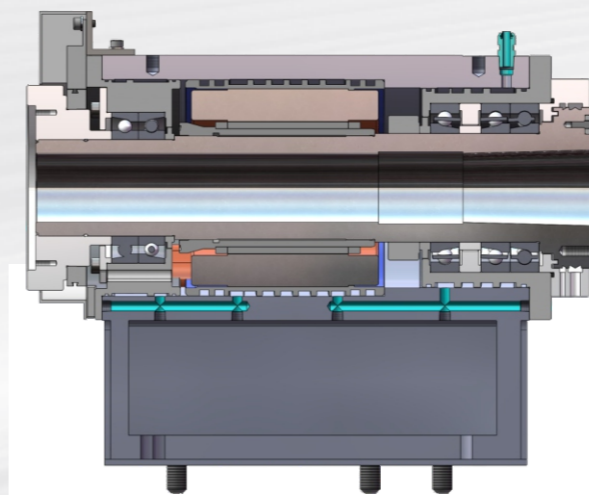

**Features of motorized spindle**

- ▶ Independently developed high-rigidity, large-through-hole, and high-torque motorized spindles to greatly improve production efficiency
- ▶ It adopts P4 grade special bearings for machine tools and is lubricated with special grease to maintain good accuracy and long service life.
- ▶ The spindle is directly driven by the built-in motor, with compact structure, reduced transmission error, high positioning accuracy and good stability.
- ▶ The spindle components are water-cooled or oil-cooled to reduce the impact of spindle heat on machining accuracy.

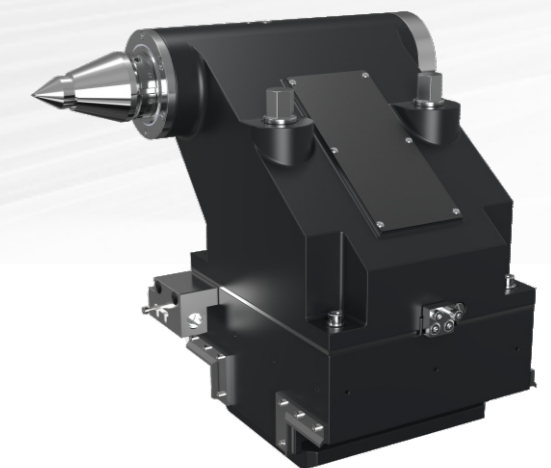

**Hydraulic telescopic tailstock**

- ▶ Tailstock live center structure, sleeve hydraulic drive, easy to operate.
- ▶ The tailstock is driven by a rectangular guide rail saddle drag pin, with high guiding accuracy.
- ▶ The sleeve has a long stroke, hydraulically clamps the workpiece, and the clamping force is adjustable to meet the processing needs of different types of products.

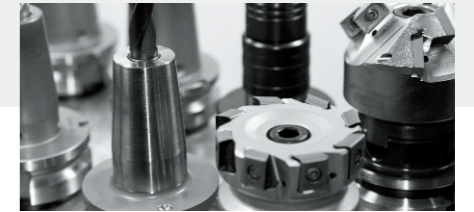

## Technology parameter

		D-L3505	D-L3505M	D-L3505MS	D-L3505MSY	D-L4505
Processing range	Max. rotation diameter on the bed (mm)	Φ610			Φ640	Φ720
	Max. processing diameter (shaft/disc) (mm)	Φ406/Φ406			Φ390/Φ480	Φ450/Φ450
	Max. processing length (mm)	560			550	560
	Max. bar diameter (mm)	Φ65		Φ52		Φ75
Travel	X-axis travel (mm)	240			215	265
	Y-axis travel (mm)	/			105(±52.5)	/
	Z-axis travel (mm)	580			580	580
	Z2 axis travel (mm)	500		580		580
Motorized spindle(S1)	Output power (S1/S6) (kw)	14.5/18			14/16	
	Spindle end form	A2-6			A2-8	
	Spindle speed (rpm)	0-4500			0-2500	
	Main spindle through hole diameter (mm)	Φ76		Φ67		Φ103
Motorized spindle(S2 sub-spindle)	Output power(S1/S6) (kw)	/		11.7/17.5		/
	Spindle end form	/		A2-5		/
	Spindle speed (rpm)	/		0-6000		/
	Main spindle through hole diameter (mm)	/		Φ57		/
Tailstock	Tailstock form and tapered hole form	Hydraulic sleeve/Mohs No. 5		/		Hydraulic sleeve/Mohs No. 5
	Tailstock sleeve travel (mm)	150		/		150
Tool turret	Tool form and tool capacity	Servo/12	Power/12			Servo/12
	Max. speed of power tool (rpm)	/	3000			/
	Cutter tool handle specifications (mm)	/	BMT55			/
	Turning tool holder specifications (mm)	25×25			25×25	
	Max. diameter of boring tool holder (mm)	Φ40				
Rapid speed	Rapid speed (X/Z axis) (m/min)	20			20	
	Rapid speed (Y axis) (m/min)	/			10	/
	Rapid speed (Z2 axis) (m/min)	20				
Feed rate	Feedrate(mm/min)	1-8000				
System	NC	Genesis system				
Chip conveyor		Automatic right chip conveyor				

All pictures in this album are for reference only and are subject to actual delivery; our company's products are constantly being improved and the above information is subject to change without prior notice.

## Technical configuration

	D-L3505	D-L3505M	D-L3505MS	D-L3505MSY	D-L4505
A2-5 counter spindle	○	○	●	●	○
A2-6 motorized spindle	●	●	●	●	○
A2-8 motorized spindle	○	○	○	○	●
6-inch hollow chuck cylinder	○	○	○	○	△
8 inch hollow chuck cylinder	●	●	●	●	○
10 inch hollow chuck cylinder	○	○	○	○	●
12-inch hollow chuck cylinder	△	△	△	△	○
Sub-spindle 6-inch solid chuck cylinder	○	○	●	●	△
8 inch solid chuck cylinder	○	○	○	○	○
10 inch solid chuck cylinder	△	△	△	△	○
12-inch solid chuck cylinder	●	○	○	○	●
Servo turret	○	●	●	●	○
Powered turret	●	●	●	●	●
12 workstations	●	●	○	○	○
Hydraulic telescopic tailstock	○	○	○	○	○
Programmable tailstock	●	●	●	●	●
Side chip conveyor (automatic)	○	○	○	○	○
Rear chip conveyor (automatic)	○	○	○	○	○
Rear chip conveyor (manual)	○	○	○	○	○
Center frame	○	○	○	○	○
Tool setter	○	○	○	○	○
Bar machine	○	○	○	○	○
Automatic material catcher	○	○	○	○	○
Oil mist collector	○	○	○	○	○
High pressure water outlet	○	○	●	●	○
Automatic door	○	○	○	○	○
Sub-spindle					
Grating scale					

● Standard configuration ○ Optional ▲ Consultable △ Non-optional





## Processing Capacity Chart

D-L3505MS

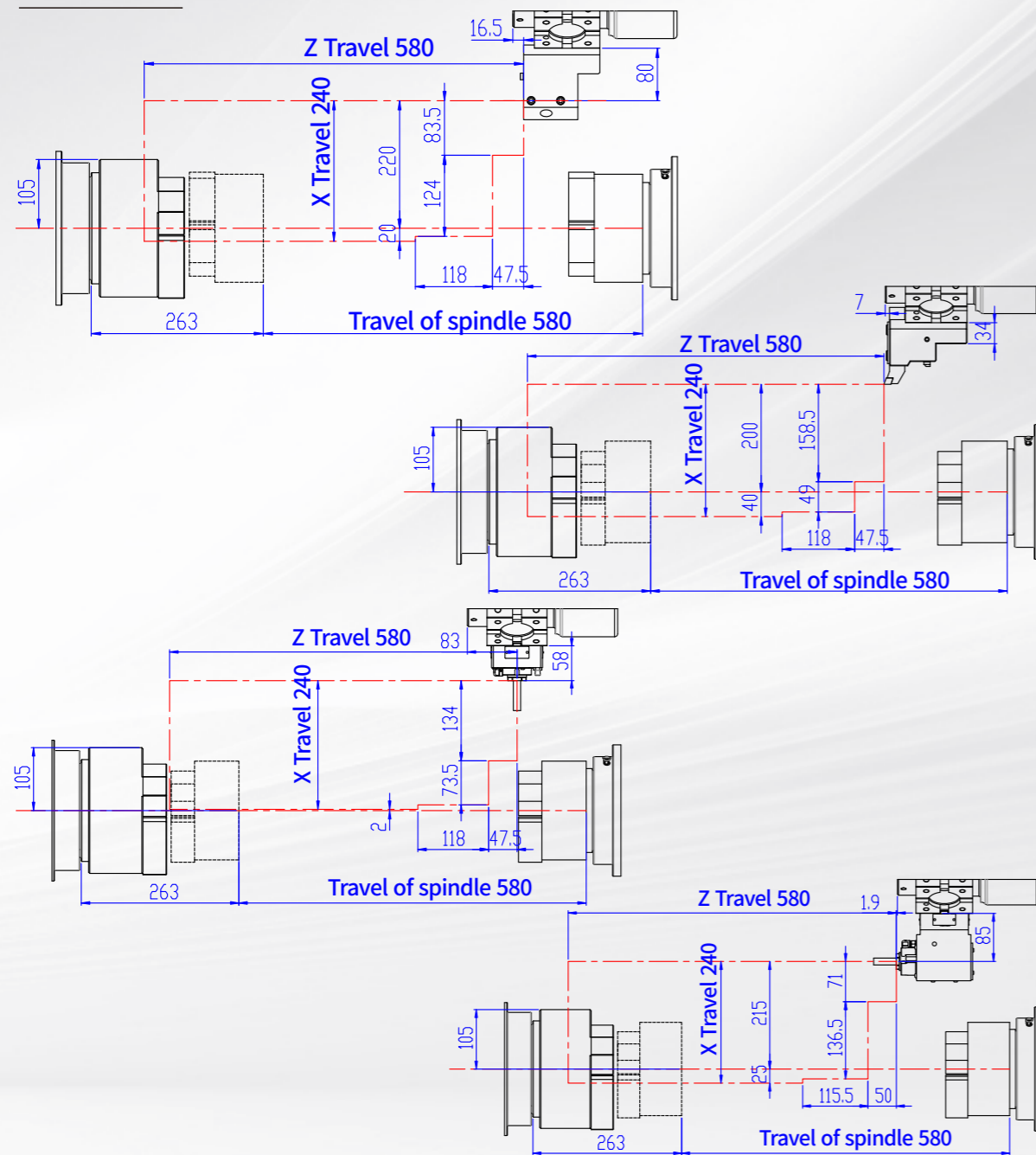

## Processing Capacity Chart

D-L3505MSY

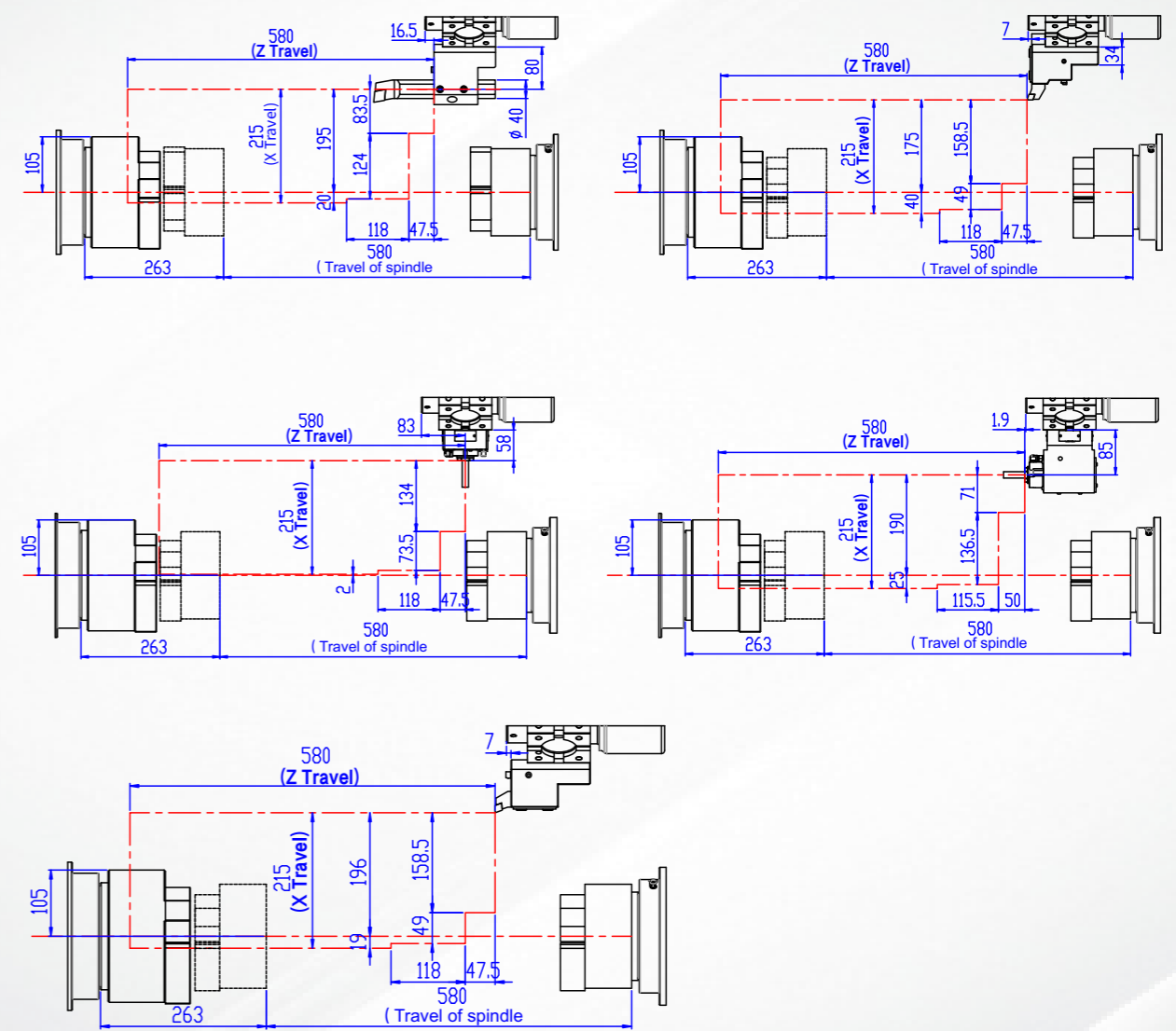



Features & Technology
Structure & Configuration
Options & Highlights
<b>Parameters &amp; sizes</b>
Machine appearance diagram

## Tool Interference Diagram

D-L3505

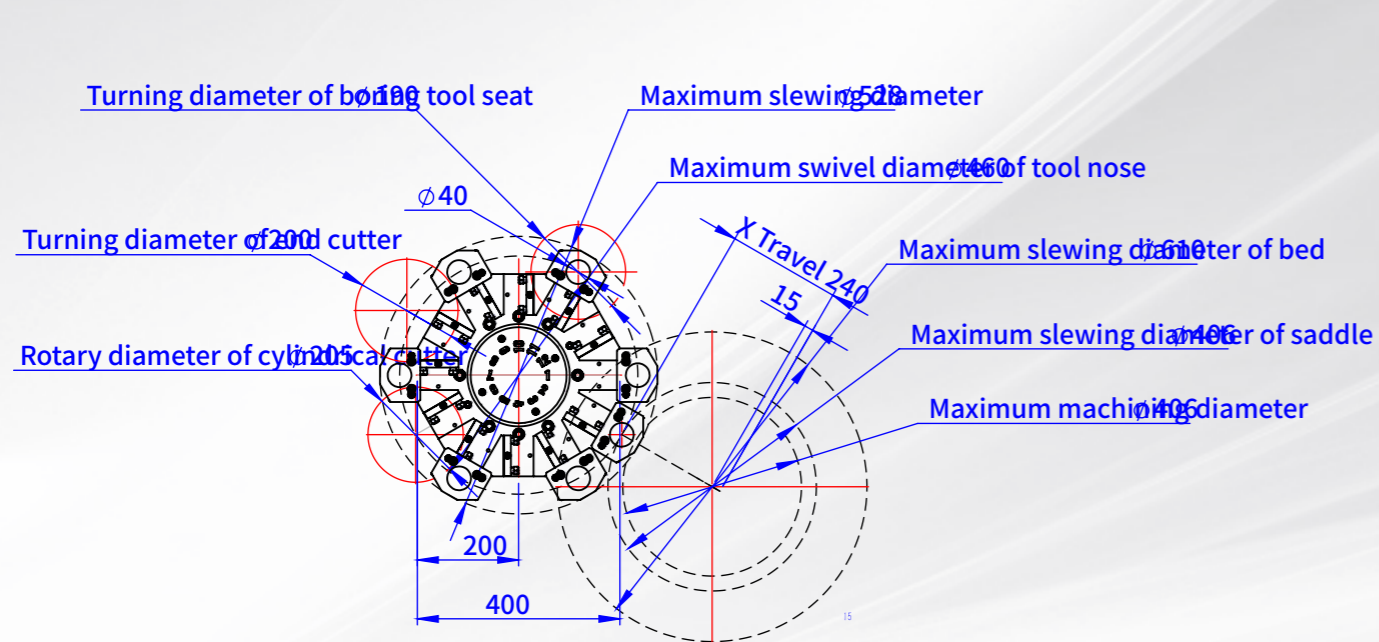

D-L4505

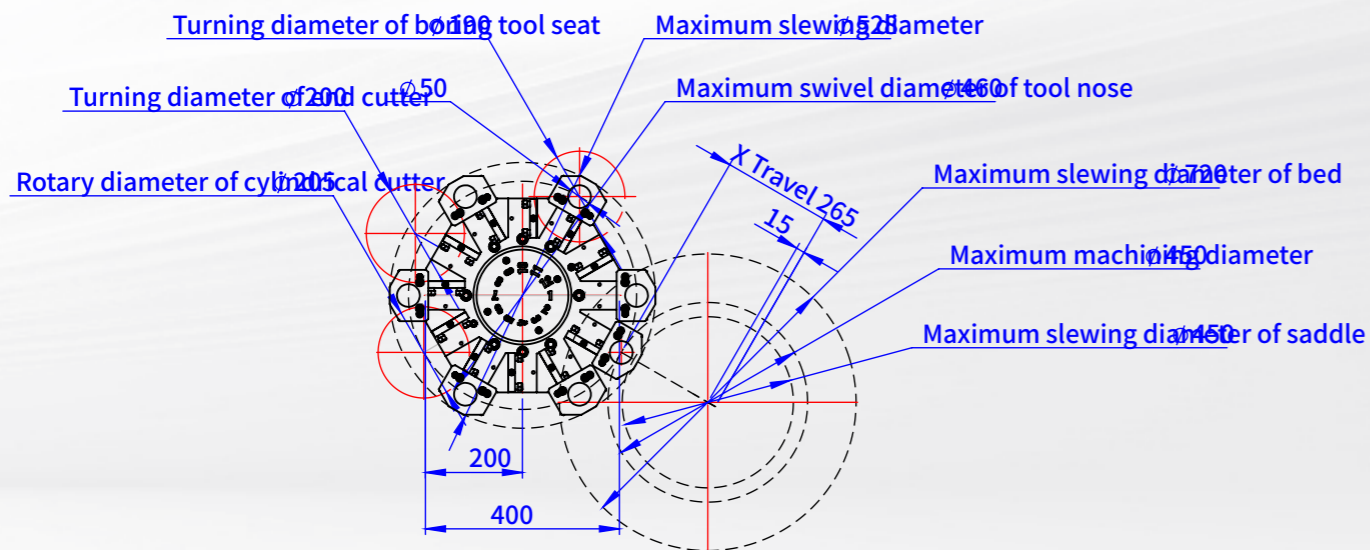

## Tool Interference Diagram

D-L3505M/D-L3505MS

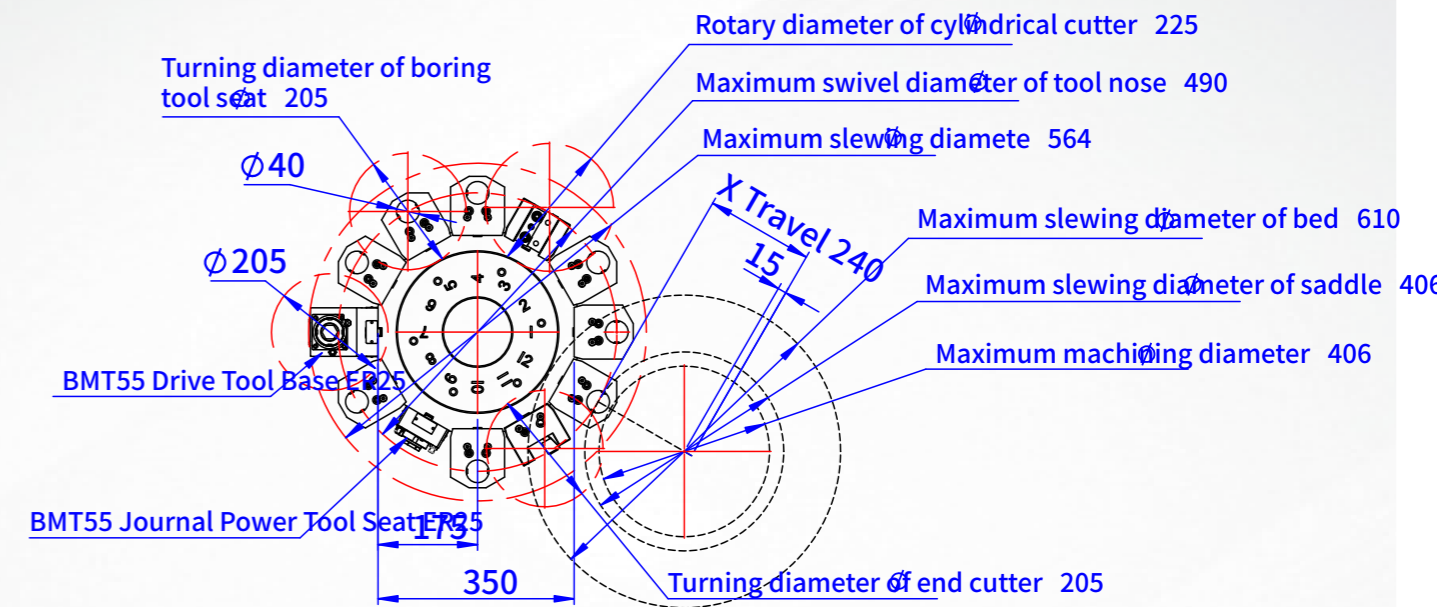

D-L3505MSY

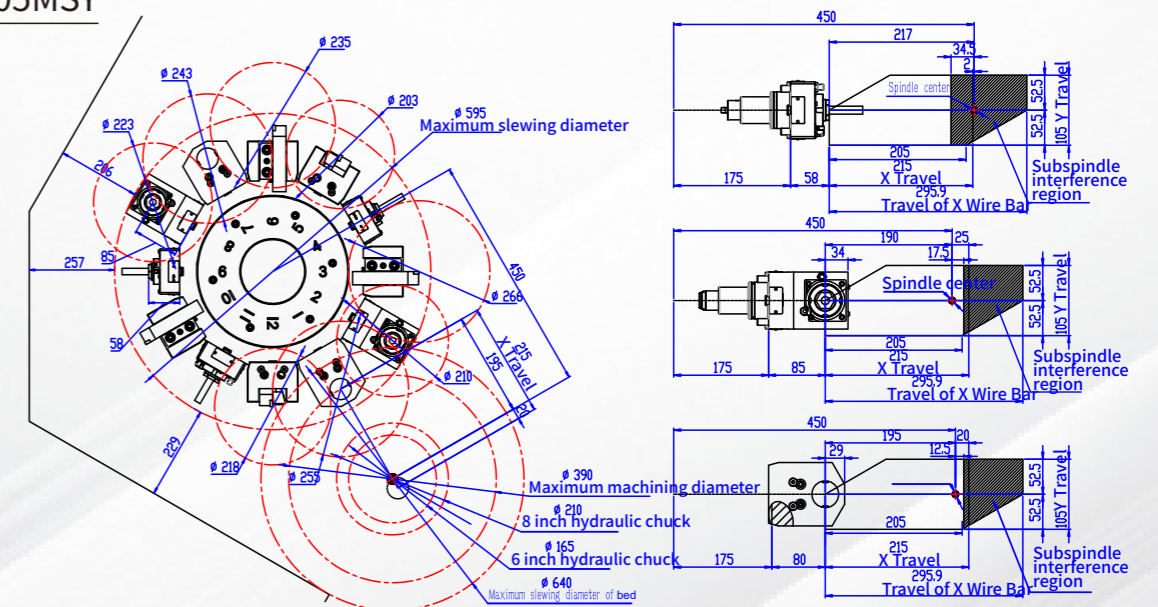



- Features & Technology
- Structure & Configuration
- Options & Highlights
- Parameters & sizes
- Machine appearance diagram**

## Machine appearance diagram

D-L3505/D-L4505/D-L3505MSY

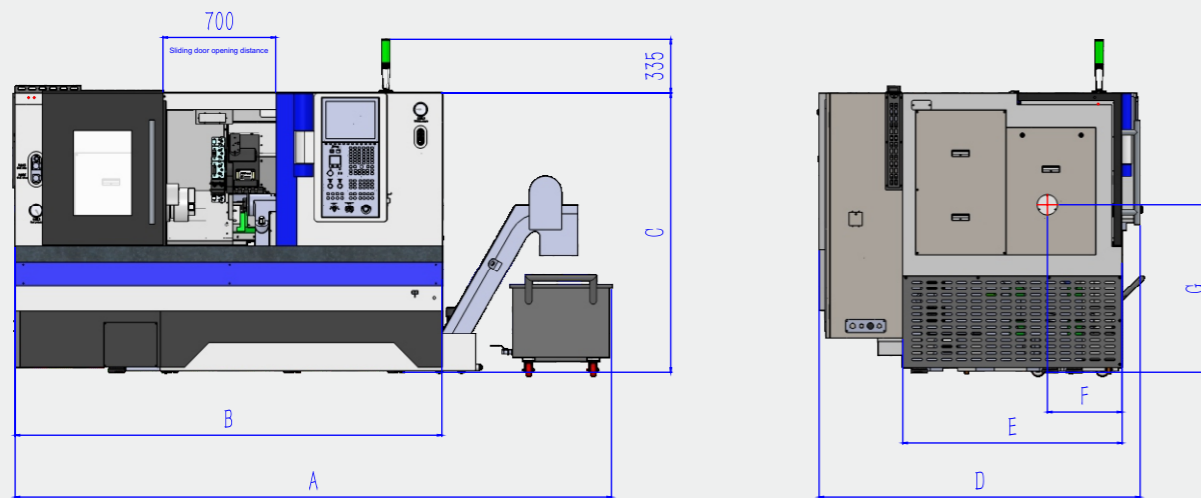

Standard size	A	B	C	D	E	F	G
D-L3505	3685	2650	1725	1980	1365	460	1030
D-L4505	3685	2650	1852	2015	1888	453	1105
D-L3505MSY	3950	2914	2137	2009	1372	435	950

**High-end intelligent equipment overall solution provider**



**Taikan**